

# OPERATING INSTRUCTIONS

## CF-71 Series



# TOUGHBOOK

95

### [Additional Manual] Reference Manual

This manual can be accessed on your computer. Please refer to page 16 on how to access the Reference Manual.

#### Contents

- Key Combinations
- LED Indicators
- Panasonic Hand Writing (Touch Pad)
- Suspend/Hibernation Functions
- Security Measures
- Computing On the Road
- Battery Power
- Using a Multimedia Pocket Device
- Using PC Cards
- Adding Memory
- Port Replicator
- Using a Printer
- Using an External Display
- Using USB Devices
- Infrared Data Communications
- Hard Disk Drive
- Setup Utility
- Technical Information
- List of Error Codes
- DMI Viewer
- Dealing With Problems

## Contents

### Getting Started

Read Me First .....	6
First-time Operation .....	7

### Operation

Starting Up/Shutting Down .....	11
Usage, Carrying and Maintenance .....	17

### Troubleshooting

List of Error Codes .....	18
Dealing With Problems .....	19
Reinstalling Software .....	22

### Appendix

LIMITED USE LICENSE AGREEMENT .....	25
Names and Functions of Parts .....	27
Specifications .....	29



<b>Customer's Record</b>	
Model No.* _____	Dealer's Name _____
Serial No. _____	_____
or	
Code No. _____	Dealer's Address _____
Date of Purchase _____	_____

\*For the Model No., insert the 11 digit number (for example, CF-71EY6GBAM) located on the bottom of the computer.

## Introduction

Thank you for purchasing the Panasonic computer. Please read the operating instructions thoroughly for proper operation of your new computer.

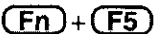
## Illustrations in this manual

<b>NOTE:</b>	<b>NOTE</b> provides a useful fact or helpful information.
<b>CAUTION:</b>	<b>CAUTION</b> indicates a condition that may result in minor or moderate injury.
<b>WARNING:</b>	<b>WARNING</b> indicates a hazard that may result in moderate or serious injury.
[Start] - [Shut Down]:	This illustration means to click [Start], then to click [Shut Down]. (For some applications, you may need to double-click.)
 :	This illustration means to press the [Enter] key.
 :	This illustration means to press and hold the [Fn] key, then press the [F5] key.
 :	Where to go for referred information.
 Reference Manual	: This illustration means to refer to the Reference Manual, which is available on your computer. Please refer to page 16 on how to access this manual.

## Copyright

This manual is copyrighted by Matsushita Electric Industrial Co., Ltd. with all rights reserved. No part of this manual may be reproduced in any form without the prior written permission of Matsushita Electric Industrial Co., Ltd. No patent liability is assumed with respect to the use of the information contained herein.

©Matsushita Electric Industrial Co., Ltd. 1998. All Rights Reserved.

## Disclaimer

Computer specifications and manuals are subject to change without notice. Matsushita Electric Industrial Co., Ltd. assumes no liability for damage incurred directly or indirectly from errors, omissions or discrepancies between the computer and the manuals.

## Trademarks

PS/2™ is a trademark of International Business Machines Corporation.

Microsoft, MS-DOS, Windows and IntelliMouse are registered trademarks of Microsoft Corporation of the United States and/or other countries.

Pentium is a registered trademark of Intel Corporation.

PhoenixCard Manager is a trademark of Phoenix Technologies Ltd.

Imation, the Imation Logo, the circle-pyramid logo, SuperDisk and SuperDisk logo are trademarks of Imation Corp.

Acrobat is a registered trademark of Adobe Systems Incorporated.

Panasonic is a registered trademark of Matsushita Electric Industrial Co., Ltd.

## For U.S.A.

### Federal Communications Commission Radio Frequency Interference Statement

Note: This equipment has been tested and found to comply with the limits for a Class B digital device, pursuant to Part 15 of the FCC Rules. These limits are designed to provide reasonable protection against harmful interference in a residential installation. This equipment generates, uses and can radiate radio frequency energy and, if not installed and used in accordance with the instructions may cause harmful interference to radio communications. However, there is no guarantee that interference will not occur in a particular installation. If this equipment does cause harmful interference to radio or television reception, which can be determined by turning the equipment off and on, the user is encouraged to try to correct the interference by one or more of the following measures:

- Reorient or relocate the receiving antenna.
- Increase the separation between the equipment and receiver.
- Connect the equipment into an outlet on a circuit different from that to which the receiver is connected.
- Consult the Panasonic Service Center or an experienced radio/TV technician for help.

### Warning

To assure continued compliance, use only shielded interface cables when connecting to a computer or peripheral. Also, any changes or modifications not expressly approved by the party responsible for compliance could void the user's authority to operate this equipment.

This device complies with Part 15 of the FCC Rules. Operation is subject to the following two conditions:

- (1) This device may not cause harmful interference, and
- (2) This device must accept any interference received, including interference that may cause undesired operation.

Responsible Party: Matsushita Electric Corporation of America  
One Panasonic Way  
Secaucus, NJ 07094  
Tel No: 1-800-LAPTOP-5 (1-800-527-8675)

## Lithium Battery

### Lithium Battery!

This computer contains a lithium battery to enable the date, time, and other data to be stored in it.

The battery should only be exchanged by service personnel. Warning! Risk of explosion from incorrect installation or misapplication!

### Avertissement concernant la pile au lithium (pile de sauvegarde)

Pile au lithium!

Le micro-ordinateur renferme une pile au lithium qui permet de sauvegarder certaines données comme la date et l'heure notamment. Elle ne devra être remplacée que par un technicien qualifié.

Avertissement! Risque d'explosion en cas de non respect de cette mise en garde!

## Precautions

This computer has been designed so as to minimize shock to the LCD and hard disk drive, the leakage of liquid (e.g., water) from the keyboard, etc., but no warranty is provided against such trouble. Therefore, as a precision instrument, please be extremely careful in the handling.

### ● Usage

#### Avoid Extreme Heat and Cold

Do not store or use the computer in locations exposed to heat, direct sunlight, or extreme cold. Avoid moving the computer between locations with large temperature differences.

Operation: 5 °C to 35 °C (41 °F to 95 °F)

Storage: -20 °C to 60 °C (-4 °F to 140 °F)

#### Avoid Direct Sunlight on the LCD Panel

The LCD panel should not be exposed to direct sunlight or ultraviolet light.

#### Avoid Humidity, Liquids and Dust

Do not store or use the computer in locations exposed to high humidity, liquids (including rain) or dust.

#### Prevent Shock

Avoid subjecting the computer to severe vibrations or impact. Do not place the computer inside a car trunk.

#### Avoid Radio Frequency Interference

Do not place the computer near a television or radio receiver.

Avoid more than casual contact with any heat producing area of the notebook computer, power adapter, and any option or accessory you use with it.

Even low heat, if warmer than body temperature, can cause a burn, if the skin is exposed to the heat source for a long enough period of time.

### ● Handling

#### Avoid Magnetic Fields

Keep the computer away from magnets.

#### Avoid Stacking

Do not place heavy objects on top of the computer.

#### Keep Small Objects Away

Do not insert paper clips or other small objects into the computer.

#### Do Not Disassemble the Computer

Do not attempt to disassemble your computer.

#### Avoid Excessive Force on the Display

Do not apply excessive downward force on the display when it is completely opened, especially when plugs and/or cables are connected to the rear of the computer.

## Precautions

### ● Peripherals

Incorrectly using peripheral devices may lead to a decrease in performance, an increase in temperature and/or damage your computer. For more information on peripheral devices, please refer to the Reference Manual.

#### CAUTION

The charging terminal of the battery pack is used with the battery charger, which is sold separately.

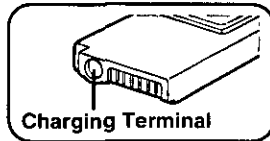

Never connect anything to the charging terminal other than the exclusive adapter that is supplied with the battery charger. Doing so could damage the device connected to the battery pack, the cable, and the battery pack itself. It could also result in overheating or bursting.

- Care should be exercised with regard to the following in order to avoid the possibility of liquid leakage, overheating, or bursting.



#### **Avoid Heat**

Do not throw the battery pack into a fire or expose it to excessive heat.



#### **Keep Articles Away**

Do not place the battery pack together with articles such as necklaces or hairpins when carrying or storing.



#### **Do Not Disassemble**

Do not insert sharp objects into the battery pack, expose it to bumps or shocks, deform, disassemble, or modify it.



#### **Do Not Short**

Do not short the positive (+) and negative (-) contacts.

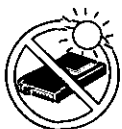

#### **Avoid Extreme Heat, Cold and Direct Sunlight**

Do not charge, use or leave the battery pack for extended periods where it will be exposed to direct sunlight, in a hot place (in an automobile on a sunny day, for example), or in a cold place.



#### **Do Not Use With Any Other Computer**

The battery pack is rechargeable and was intended for the specified computer or charger. Do not use it with a computer other than the one for which it was designed.



#### **Do Not Put into a Microwave**

Do not put the battery pack into a microwave oven or a pressurized chamber.

### Discontinue Use



Should the battery emit an abnormal odor, become hot to the touch, become discolored, change shape, or become in any way different from normal, remove it from the computer or charger and discontinue use.

- Do not touch the terminals on the battery pack. The battery pack may no longer function properly if the contacts are dirty or damaged.
- Do not expose the battery pack to water, or allow it to become wet.
- If the battery pack will not be used for a long period of time (a month or more), charge or discharge (use) the battery pack until the remaining battery level becomes 30% to 40% and store it in a cool, dry place.
- This computer prevents overcharging of the battery by recharging only when the remaining power is less than approx. 95% of capacity.
- The battery pack is not charged when the computer is first purchased. Be sure to charge it before using it for the first time. When the AC adapter is connected to the computer, charging begins automatically.
- Should the battery leak and the fluid get into your eyes, do not rub your eyes. Immediately flush your eyes with clear water and see a doctor for medical treatment as soon as possible.

#### NOTE

- The battery pack may become warm during recharging or normal use. This is completely normal.
- Recharging will not commence outside of the allowable temperature range (0 °C to 35 °C (32°F to 95 °F)). Once the allowable range requirement is satisfied, charging begins automatically. Note that the recharging time varies based on the usage conditions. (Recharging takes longer than usual when the temperature is 10 °C (48 °F) or less.)
- If the temperature is low, the operating time is shortened. Only use the computer within the allowable temperature range.
- Although the battery has remaining capacity, the battery indicator may light up red or emit a beep. This indicates a significant rise in the temperature of the battery pack. This is typically caused by the fact that the battery pack has been delivering a high level of power because the computer has been used with the display at the brightest setting and with the power-saving function off. To protect the battery pack from increases in temperature, the brightness of the display automatically decreases, allowing the temperature of the battery to drop. In this condition, if the computer is left as is, it will automatically go off after about three minutes have elapsed. Within that period, therefore, be sure to connect the AC adapter or shut the computer OFF after saving any open data (if necessary).

**CAUTION!**

THIS PRODUCT UTILIZES A LASER.

USE OF CONTROLS OR ADJUSTMENTS OR PERFORMANCE OF PROCEDURES OTHER THAN THOSE SPECIFIED HEREIN MAY RESULT IN HAZARDOUS RADIATION EXPOSURE.

DO NOT OPEN COVERS AND DO NOT REPAIR YOURSELF.

REFER SERVICING TO QUALIFIED PERSONNEL

**AVERTISSEMENT!**

CET APPAREIL UTILISE UN LASER.

L'UTILISATION DE COMMANDES OU DE RÉGLAGES OU L'EXÉCUTION DE PROCÉDURES AUTRES QUE CELLES SPÉCIFIÉES ICI PEUVENT PROVOQUER UNE EXPOSITION À DES RADIATIONS DANGEREUSES.

NE PAS OUVRIR LES COUVERCLES NI ESSAYER DE RÉPARER SOI-MÊME.

CONFIER TOUT TRAVAIL D'ENTRETIEN À UN PERSONNEL QUALIFIÉ.

**WARNUNG!**

DIESES PROUKT ERZEUGT LASERSTÄHLUNG.

DURCHFÜHRUNG ANDERER VORGÄNGE ALS DER HIER ANGEGEBENEN KANN ZU GEFÄHRLICHER STRAHLUNG FÜHREN.

REPARATUREN DÜRFEN NUR VON QUALIFIZIERTEM FACHPERSONAL DURCHGEFÜHRT WERDEN.

**VARNING**

Om apparaten används på annat sätt än i denna bruksanvisning specificerats, kan användaren utsättas för osynlig laserstrålning, som överskrider gränsen för laserklass 1.

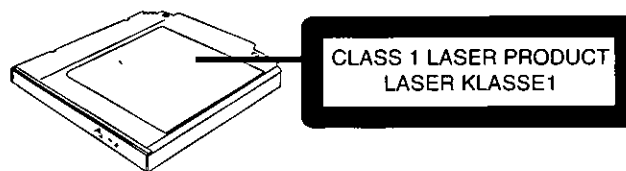

# Read Me First

## Saving Data on the Hard Disk

- **Do not expose your computer to shock.**  
Please use care when handling your computer, shock may damage your hard disk or make your software applications and data unusable.
- **Do not power off your computer while software applications are running or HDD indicator (HDD) is on.**  
Properly shut Windows\* down to avoid problems ([Start] - [Shut Down] ).
- **Save all valuable data to floppy disks.**  
Backing up data to floppy disks will limit damage should trouble occur to your computer or should you inadvertently change or erase data.
- **Use the security function for all important data.** (  Reference Manual "Security Measures")

\* This computer uses Microsoft® Windows® 95 Operating System.

## Saving Data on Floppy Disks

- **Do not power off your computer or press the floppy disk drive eject button while the MP indicator (MP) is on.**  
Doing so may damage the data on the floppy disk and render the disk useless.
- **Use care when handling floppy disks.**  
To protect the data on your floppy disks or to prevent a floppy disk from becoming stuck in your computer, avoid the following:
  - Sliding the shutter on the floppy disk manually.
  - Exposing the disk to a magnetic field.
  - Storing the disk in locations prone to high temperatures, low pitched noise, dampness, or dust.
  - Applying more than one label on the disk.
- **Confirm the contents of a floppy disk before formatting it.**  
Confirm that no important data is on the disk, because all data on the disk will be erased.
- **Use the write-protect tab.**  
This is a must for preserving important data. This prevents your data from being erased or overwritten.



Write Enable

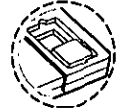

Write Disable

## Computer Viruses

- **Users are advised to purchase the latest versions of virus protection software and use them regularly.**  
We recommend you run the software:
  - When booting your computer.
  - After receiving data.We recommend that you check data received on floppy disks or from external sources, such as data downloaded from the Internet, e-mail, etc. (For compressed files, please uncompress them before running a check).

# First-time Operation







Please read the steps below to help you learn what parts are included, and to gain an understanding of some basic computer-related operations.

## 1 Confirm the inclusion of all parts

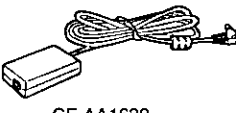
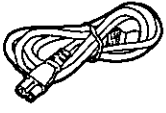
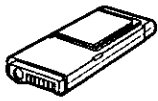
Make sure the parts shown in the figure have been supplied. If any of these items are missing or is not working properly, please contact Panasonic Technical Support.

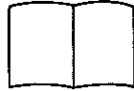
### CAUTION

Have 2HD floppy disks prepared to create disks that will allow you to reinstall the operating system should a problem occur. Be sure that these disks are not write-protected. (It is not necessary for these disks to be preformatted.)

AC Adapter ..... 1  CF-AA1639	AC Cord ..... 1 
Battery Pack ..... 1  CF-VZSU09	CD-ROM Pack ..... 1  CF-VCD711
FIRSTAID CD ..... 1 	Operating Instructions ..... 1 
Windows 95 System Pack .... 1	
 Windows® 95 Book  CD-ROM  Registration Card	

Using a CD-ROM pack  Reference Manual "Using a Multimedia Pocket Device"

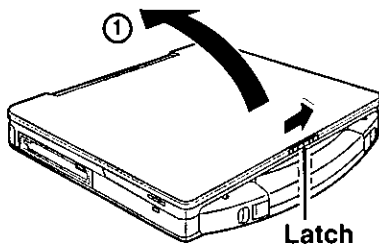

## 2 Connect the battery pack

- Slide the latch located at the front and lift open the display.

# First-time Operation

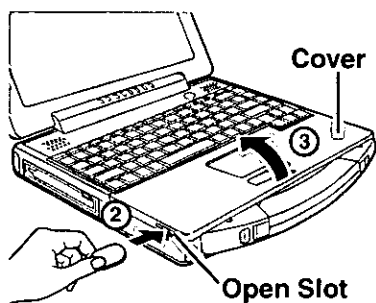

② Insert a thin, flat object, like a ruler into the open slot on the left side of the computer.

③ Open the cover.

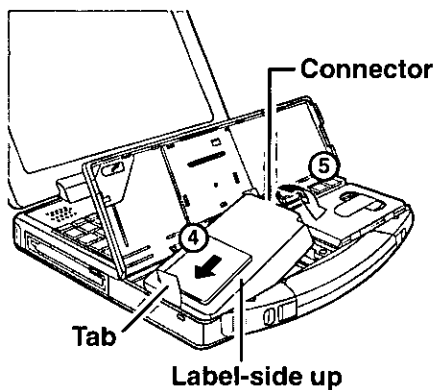

④ Pull the tab outside the frame of the computer, and insert the non-connector-side of the battery pack into the computer with the label-side up.

⑤ Insert the connector-side of the battery pack into the computer to secure the connector.

## CAUTION

- Be sure the battery pack is properly connected to the connector.
- If the tab is set under the battery pack, the battery pack will be difficult to remove later.
- Do not touch the battery connector on the computer and flat cable. The computer may not operate properly.

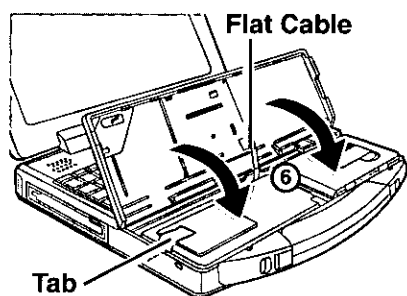

⑥ Close the cover until it clicks into place; be sure the tab does not get caught when closing the cover.

## CAUTION

### When closing the cover;

- Be careful not to get your fingers caught in the cover.
- There are instances the right side of the cover will float. In such cases, attempt to close the cover again by putting the projection on the right side of the cover below the keyboard.

Press down on these areas firmly.

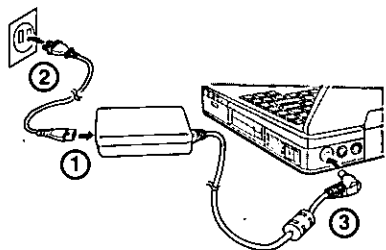
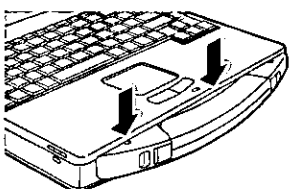

## 3 Connect your computer to a power outlet

### CAUTION

Be sure the AC adapter is connected until completing Step 8 on page 10.

### Handling the AC adapter

- Do not twist or pull the AC power cord forcefully. Doing so may damage the connections.
- Use only the specified AC adapter with your computer. Using an AC adapter other than the one supplied might damage the battery and/or the computer.
- When the DC plug is not connected to the computer, disconnect the AC cord from your AC wall outlet.
- Problems such as sudden voltage drops/surges may arise during periods of thunder and lightning. Since this could adversely affect your computer, an uninterruptible power source (UPS) is highly recommended unless the battery pack is installed.



## 4 Read the LIMITED USE LICENSE AGREEMENT (page 25)

Before removing the seal covering the power switch, please read the LIMITED USE LICENSE AGREEMENT. Removal of this seal indicates agreement to the terms specified. After you have agreed to the terms, you may turn your computer on.

## 5 Turn your computer on

Slide the power switch toward the rear of the computer and hold it for approximately one second until the power indicator turns on before releasing it.

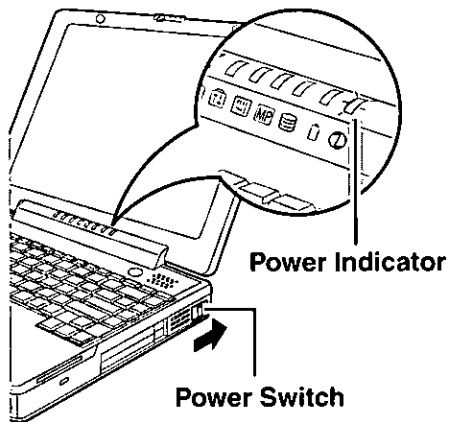

### CAUTION

- After confirming that the power indicator has turned on, do not touch the power switch until Windows setup has started.
- Once the computer is powered off, you must wait at least ten seconds before powering it on again.

### NOTE

The power saving function is factory set, so if there is no input from a key, the touch pad, or the external mouse for two minutes, the power to the LCD is cut (ECO mode).

The LCD will resume operation when the touch pad is used or a key is pressed.

The computer may enter the ECO mode while Windows is setting up or even when an application software is being installed. In this case, because it is conceivable that a selection dialog box will be shown, for resuming from the ECO mode, do not press **Enter** which may trigger a selection, but instead, press a key unrelated to the direct triggering of a selection, like **Shift**.

## 6 Setup Windows 95

- ① Select settings for your region, then press [Next].

### NOTE

Moving the cursor (↔) or clicking buttons can be performed with the touch pad. (page 13)

- ② Select your keyboard layout, then press [Next].  
(for U.S.A.: United States 101)
- ③ Enter your name and your company's name, then press [Next].  
(It is possible to omit the company name item.)  
The License Agreement will be displayed.
- ④ After reading the agreement, select [I accept the agreement] or [I don't accept the agreement], then press [Next].

### NOTE

If [I accept the agreement] is selected, the [Certificate of Authenticity] will appear. If [I don't accept the agreement] is selected, the Windows setup will be aborted.

- ⑤ Input the Product Number written on the "Certificate of Authenticity" located in the Windows® 95 book that comes with this computer then press [Next].
- ⑥ Press [Finish].

# First-time Operation

- ⑦ Input the correct date, time and time zone and press [Close].  
You can also complete these settings at a later time.
- ⑧ If you wish to complete the printer settings, press [Next]. If not, press [Cancel].

## NOTE

Simply follow the on-screen instructions. You can also complete these settings at a later time.

## 7 Create floppy disks

Prepare 2HD floppy disks and make sure they are not in the write-protected state, then select [Start] - [Programs] - [Panasonic] - [Create FIRSTAID FD] and follow the on-screen instructions. Place a label identifying the contents on each disk.

### ● Name of created backup disk

FIRSTAID FD

(When the display for creating the BACKUP DISK is shown, create the disk by following the on-screen instructions.)

## CAUTION

- Please store the floppy disks in a safe place. They will enable you to return your computer to close to the condition at the time of purchase should any problems occur.  
When creating floppy disks, do not run any other application program.
- When creating floppy disks and the message [Insufficient files to copy] is displayed, click [OK] and then contact Panasonic Technical Support.
- While the MP indicator (MP) is on, do not remove the floppy disk, power down your computer or use the suspend or hibernation function (☞ Reference Manual "Suspend/Hibernation Functions").

## 8 Install the Acrobat® Reader 3.01

## NOTE

Acrobat® Reader is necessary to view the Reference Manual, which explains detailed operational procedures concerning your computer.

- ① In [Start] - [Run], input [c:\util\avapp\reader\ar32e301.exe], then press [OK].  
When the [This will install Adobe Acrobat Reader 3.01. Do you wish to continue?] appears, press [Yes].
- ② Press [Next] and set up the Acrobat® Reader 3.01.
- ③ After reading the "Software License Agreement", select [Yes] if you agree to the terms.
- ④ Press [Next].
- ⑤ Press [Finish].  
Read the [Readme] file as necessary. To close the file, click  in the top right corner of the window.
- ⑥ Press [OK].

**This concludes the first-time use operation guidelines.**

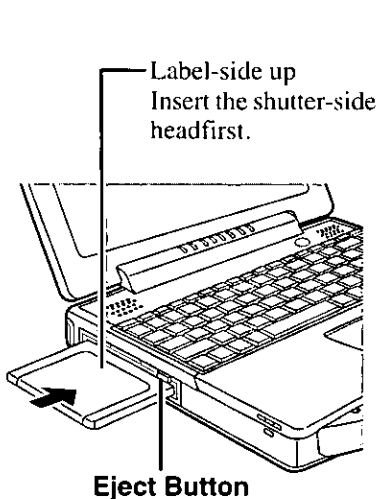

# Starting Up/Shutting Down

## Starting Up

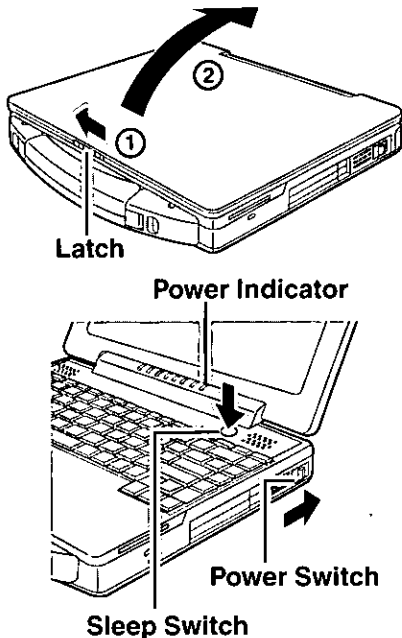

### 1 Open the display

Slide the latch as shown and lift open the display.

### 2 Turn your computer on

The following two methods are available.

- Slide the power switch toward the rear of the computer and hold it for approximately one second until the power indicator turns on before releasing it.
- Press the sleep switch\* and hold it until the power indicator turns on before releasing it.

\*Power cannot be turned on with the sleep switch when the power goes off by holding down the sleep switch for more than four seconds, or when both the AC adapter and battery pack are reconnected after having been disconnected.

#### CAUTION

- The computer will not power on when the display is closed.
- After confirming that the power indicator has turned on, avoid the following until Windows has completed loading.
  - Touching the power switch or the sleep switch.
  - Performing any keyboard or touch pad (or external mouse) operations.
  - Closing the display.

If the display is closed while Windows is starting up, it is possible that color, etc., will not be displayed properly. Run the [MS-DOS Prompt] ([Start] - [Programs] - [MS-DOS Prompt]), and use full screen display mode by pressing **Alt** + **Enter**. After returning from the full screen mode (**Alt** + **Enter** again), the display will be shown correctly.

- Once the computer is powered off, you must wait at least ten seconds before powering it on again.
- When the CPU temperature rises, the computer may not power on to prevent the CPU from overheating. Should this happen, allow the computer to cool down then switch the power on again.

If the computer still does not power on, please contact Panasonic Technical Support.

### ● If security indicator (🔒) is displayed,

you must first enter your User Password. (📖 Reference Manual "Security Measures")

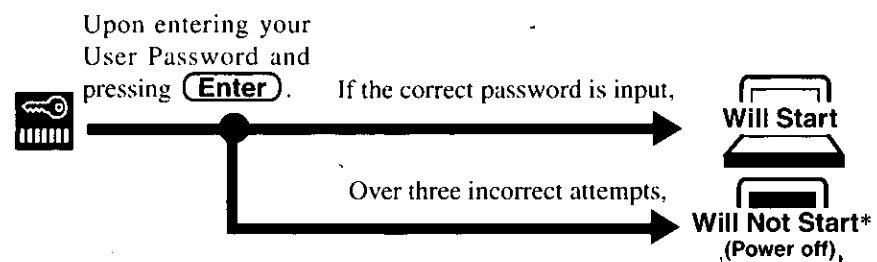

\* If you are starting from the suspend mode (📖 Reference Manual "Suspend/Hibernation Functions"), if after three attempts the correct password is not input, or if no password is entered for about a minute, the computer returns to the suspend mode.

### ● When an application or file that was previously displayed appears on your screen,

the suspend or hibernation function has been set. (📖 Reference Manual "Suspend/Hibernation Functions")

# Starting Up/Shutting Down

## 3 Select your application

You are able to start working on your computer.

### NOTE

- The power saving function is factory set, so if there is no input from a key, the touch pad, or the external mouse for two minutes, the power to the LCD is cut (ECO mode).  
The LCD will resume operation when the touch pad is used or a key is pressed.
- [System Devices] in [Start] - [Settings] - [Control Panel] - [System] - [Device Manager] may contain a device or devices bearing an exclamation mark or question mark. This does not indicate a malfunction. Such a mark (exclamation or question mark) will not be displayed if the operating environment of the device showing the mark is corrected, by for instance installing the driver of the device.

## Using the Touch Pad

Use the touch pad to move the cursor on the display and perform normal computer operations. For instructions on how to handle the touch pad, refer to page 13.

The touch pad has the following two modes of operation.

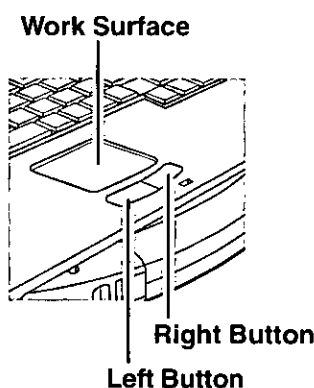

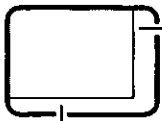
Microsoft® IntelliMouse™ Wheel Mode (Setting at the time of purchase)	Original Mode
<p>Wheel mode operations (almost identical to the case of using the Microsoft® IntelliMouse™ for scroll, zoom, etc., operations) are possible for Microsoft® wheel function-compatible applications.</p> <p>Microsoft® IntelliMouse™ is a mouse-type device that, in addition to the two conventional buttons, incorporates a wheel able to rotate forwards/backwards.</p>	<p>Only scroll operation is possible for applications not compatible with the Microsoft® wheel function.</p> <p>Even for applications compatible with the Microsoft® wheel function, there are cases where only vertical scrolling or only horizontal scrolling is possible in this mode.</p>
<p><b>Scrolling Area</b></p>  <p>Scrolling up/down</p> <p>For the Pan and Auto Scroll functions, the entire work surface of the touch pad can be used for scrolling.</p>	<p><b>Scrolling Area</b></p>  <p><b>Scrolling up/down</b> Possible when a check mark ✓ is added for [Vertical].</p> <p><b>Scrolling side-to-side</b> Possible when a check mark ✓ is added for [Horizontal].</p>

: Typical mouse operations use this area.

When no check mark is added for [IntelliMouse Wheel mode], [Horizontal] and [Vertical] of [Scroll Configuration], the entire surface can be used for typical mouse operations.

### NOTE

When you are not sure whether an application is compatible with the Microsoft® wheel function or not, try using both modes. Furthermore, depending on the application, there are cases where scrolling may not be possible with either mode.







## ● Changing the mode of the touch pad

- 1 Select  from the taskbar or select [Motion] in [Start] - [Settings] - [Control Panel] - [Mouse].
- 2 ● To set the Microsoft® IntelliMouse™ Wheel mode  
Add the check mark ✓ for [IntelliMouse Wheel mode] of [Scroll Configuration].  
● To set the original mode  
Delete the check mark for [IntelliMouse Wheel mode] of [Scroll Configuration] and add the check mark ✓ for [Horizontal] and/or [Vertical].
- 3 Press [OK].

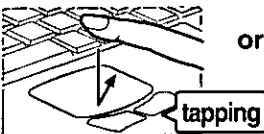
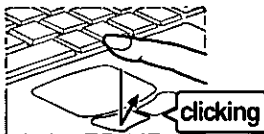
## Basic Operation

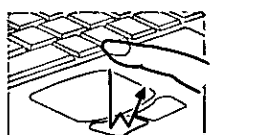
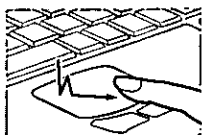
**Wheel** Indicates an operation applicable to the Microsoft® IntelliMouse™ Wheel mode.

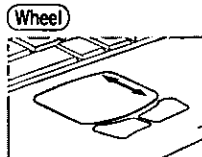
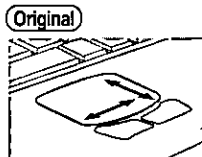
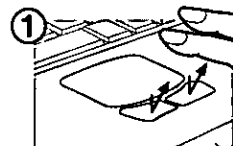
**Original** Indicates an operation applicable to the original mode.

Function	Touch Pad Operation
<b>Moving the Cursor</b> <b>Wheel</b> <b>Original</b>	 <p>Move the tip of your finger lightly over the surface.</p>
<b>Tapping/Clicking</b> <b>Wheel</b> <b>Original</b>	 <p>tapping</p> <p>or</p>  <p>clicking</p>
<b>Double-Tapping/ Double-Clicking</b> <b>Wheel</b> <b>Original</b>	 <p>double-tapping</p> <p>or</p>  <p>double-clicking</p>
<b>Dragging</b> <b>Wheel</b> <b>Original</b>	 <p>or</p>  <p>Two quick taps, but on the second tap leaving your finger down (applying pressure) and moving it on the work surface.</p> <p>While holding down the button, moving your finger on the work surface.</p> <p>● When a check mark ✓ is added for [use Drag Lock] *</p> <p>After the drag operation (above : left side), it is necessary to determine the destination (i.e., location of drop) by one tap. Under the condition no destination is selected, do not use the suspend or hibernation function. Nothing is shown on the display, even after resuming from the suspend or hibernation mode.</p> <p>In this case, the display will return after a tap or click is made.</p> <p>* In [Start] - [Settings] - [Control Panel] - [Mouse] - [Tap and Buttons]</p>
<b>Scroll*</b> <b>Wheel</b> <b>Original</b>	 <p>Wheel</p>  <p>Original</p> <p>Scroll a document (rotate the wheel)</p>
<b>Auto Scroll*</b> <b>Wheel</b>	 <p>①</p>  <p>②</p> <p>Operate after pressing the two buttons simultaneously.</p> <p>● When releasing the auto scroll function: One tap on the work surface.</p>

# Starting Up/Shutting Down

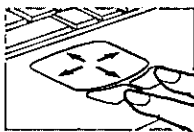
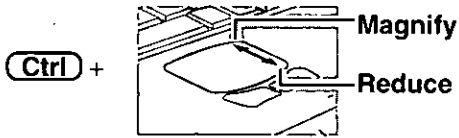
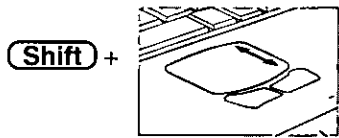
Function	Touch Pad Operation
<b>Pan*</b> <span style="float: right;">(Wheel)</span> Scroll in various directions of a document (move the mouse slightly while holding down the wheel)	 Operate while holding down the two buttons.
<b>Zoom*</b> <span style="float: right;">(Wheel)</span> Magnify/reduce the display of a document. (rotate the wheel while holding down <b>(Ctrl)</b> )	 (Ctrl) + Magnify/Reduce
<b>Data Zoom*</b> <span style="float: right;">(Wheel)</span> Display or hide a document, or perform operations to return to or proceed with Internet Explorer. (rotate the wheel while holding down <b>(Shift)</b> )	 (Shift) +

Within the parentheses ( ) are operations to follow when using an external Microsoft® IntelliMouse™.

\* Indicates that the movements will differ depending on the application.

## CAUTION

- Do not enter the suspend or hibernation mode when an external mouse is connected to the serial port.
- When an external mouse or trackball with additional functions (e.g., wheel function) is connected, a part or all of the additional functions may not function. To use these additional functions, install the driver or application software of the external device by following the procedure below. However, once the driver or application software is installed, it is possible that part of the functions of the touch pad (e.g., auto scroll) will no longer operate even when the touch pad is enabled again (see the procedure for "When you want to re-enable the touch pad.").

1 Select [Mouse] in [Start] - [Settings] - [Control Panel].

2 Select [General] in [Mouse Properties], and then select [Change].

3 Select [(Standard mouse types)] for [Manufacturers:], select [Standard PS/2 Port Mouse] for [Models:], then select [OK].

4 Select [Close]. At the message asking whether to restart the computer, select [No].

5 Power off your computer (☞ page 15) and connect the external mouse or trackball device to the computer.

6 Turn the power on and run the Setup Utility (☞ <sup>Reference Manual</sup> "Setup Utility"). In [Main] menu, set [Touch Pad] to [Disable] and close the Setup Utility.

7 Following the operating instructions for the connected external mouse, install the necessary driver.

After the installation, be sure to [Disable] setting for [Touch Pad] of the Setup Utility.

### When you want to re-enable the touch pad;

1 Perform steps 1 to 4 of the procedure shown above.

2 Power off your computer (☞ page 15) and remove the external mouse or trackball device.

3 Turn the power on and run the Setup Utility (☞ <sup>Reference Manual</sup> "Setup Utility"). In [Main] menu, set [Touch Pad] to [Enable] and close the Setup Utility.

4 Perform steps 1 and 2 of the procedure shown above. select [Matsushita] for [Manufacturers:] and [Touch Pad] for [Models:], then select [OK].

5 Select [Close]. At the message asking whether to restart the computer, select [Yes].

### NOTE

The double-tapping speed of the touch pad cannot be changed, even if the setting for [Double-click Speed] in [Start] - [Settings] - [Control Panel] - [Mouse] - [Tap and Buttons] is changed.

## Handling the Touch-Pad

- Do not place any object on the work surface or press down forcefully with sharp-pointed objects (i.e. nails), hard objects or objects leave marks (i.e. pencils and ball point pen).
- Do not allow things that could dirty the touch pad, such as oil. The cursor may not work properly in such cases.
- When the touch pad becomes dirty:  
Wipe to remove dirty areas by using a dry soft cloth such as gauze or a soft cloth first applied with detergent diluted with water and then thoroughly wrung.  
Do not use benzene or thinner, or disinfectant-type alcohol.

## Using a CD-ROM Pack

Please refer to <sup>Reference Manual</sup> "Using a Multimedia Pocket Device" on precautions and how to install or remove a CD-ROM Pack.

## Shutting Down (power off your computer)

This procedure is shutting down without using the suspend or hibernation function.

(☞ <sup>Reference Manual</sup> "Suspend/Hibernation Functions")

### 1 Display the shut down screen

After saving important data and closing each application, select [Shut Down] from the [Start] menu.

### NOTE

From the keyboard,

You may choose to press down on , then select the menu with  or .

### 2 Confirm shut down

Select [Shut down].

Your computer will power off automatically.

(In the OFF state, if you are not recharging your battery pack or if the pack is fully charged, your computer consumes approximately 1.5 W.)

### ● Restarting your computer (without shutting down)

Select [OK] after selecting [Restart].

### NOTE

To quickly resume computer operation after shutting down,

The suspend or hibernation function is available. (☞ <sup>Reference Manual</sup> "Suspend/Hibernation Functions")

# Starting Up/Shutting Down

## About the Reference Manual

The Reference Manual can be accessed on your computer. When a printer is connected, it is also possible to print.

This manual explains functions for you to make greater use of the computer, such as how to add peripheral devices, how the Setup Utility works and other useful information.

### CAUTION

When you read the Reference Manual, it is necessary to install the Acrobat® Reader 3.01. (☞ page 10)

### Run the Reference Manual

**1** Turn your computer on

**2** Select [Reference Manual] in [Start] - [Programs] - [Panasonic]

**Zoom-in**  
Go forward or back a page, or to the beginning or end of a document.

**Hand tool**  
To move around the current page.

**Cancel or correct an operation**

**Change the display size**

**Perform a "find" operation**

**Exit**

**Table of Content (Items)**  
By clicking an item, the corresponding page will be displayed at 100%.

**Display of the manual**

**Movable splitter bar**  
This bar can be dragged, for example, to the right to enlarge the display of the Table of Contents.

**Change the display size**  
You can choose to magnify/de-magnify the display.

**Page indicator**  
A desired page can be displayed by inputting the page number after clicking here.

(The display may be changed without notification.)

**Contents**

Contents	
Key Combinations	2
LED Indicators	3
Panasonic Hand Writing (Touch Pad)	4
Suspend/Hibernation Functions	6
Security Measures	9
Computing On the Road	14
Battery Power	17
Using a Multimedia Pocket Device	21
Using PC Cards	23
Adding Memory	25
Port Replicator	26
Using a Printer	27
Using an External Display	28
Using USB Devices	29
	31

### CAUTION

- Illustrations may be difficult to view depending on the magnification. If this is the case, we recommend that the display be magnified.
- When the taskbar is hidden at the bottom portion of Acrobat® Reader, set the maximum display window size.
- If a printer is connected, we recommend printing pages. The illustrations and display samples may not print with a high quality.



# Usage, Carrying and Maintenance

## Usage Environment

### ● Environment

- Place the computer on a flat stable surface.
- In use: Temperature: 5 °C to 35 °C (41 °F to 95 °F)  
Humidity: 30% to 80% RH (No condensation)
- Not in use: Temperature: -20 °C to 60 °C (-4 °F to 140 °F)  
Humidity: 30% to 90% RH (No condensation)

### ● Places not to use your computer

- Such areas may result in damage to the computer.

**Areas exposed to direct sunlight**

**Areas with electronic equipment**

These areas may interfere with your display or cause your computer to produce strange sounds.

**Areas with extremely high/low temperatures**

- Do not leave things near the computer that are sensitive to heat. During operation, the computer may become warm.

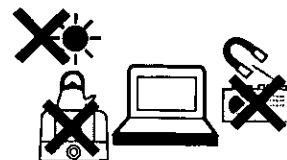

## Transporting

- This computer has been designed so as to minimize shock to the LCD and hard disk drive, the leakage of liquid (e.g., water) from the keyboard, etc., but no warranty is provided against such trouble. Therefore, as a precision instrument, please be extremely careful in the handling.
- Do not drop or hit your computer against solid objects.
- It is a good idea to make backup copies on floppy disks and carry them with you.
- Do not leave a floppy disk in the drive while transporting your computer.
- Do not carry your computer when it is ON.
- Remove all cables before transporting your computer. Having the optional port replicator is very convenient.
- We recommend preparing a fully charged battery (and optional charger, if possible). When transporting spare batteries inside a package, briefcase, etc., it is recommended that the batteries be stored in a plastic bag.
- Do not place the computer upright. When the computer receives shock after falling, the hard disk or floppy disk drive, etc., may become inoperable.
- Do not carry the computer while the display is open, or carry it by gripping the display.
- Do not put anything (e.g., a piece of paper) between the display and keyboard.
- Always carry your computer with you. Never check it in with luggage. For use of the computer inside an aircraft, we recommend asking the airlines regarding their policy on this issue.

## Maintenance

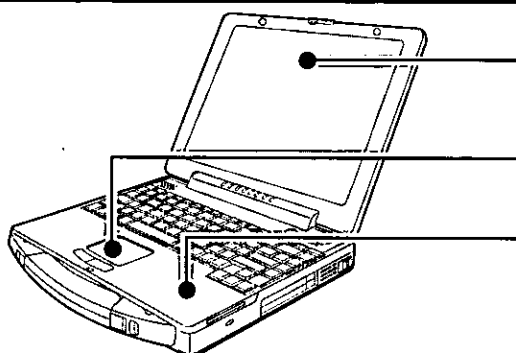

### Display

Use a soft dry cloth like gauze to lightly wipe the display.

### Touch Pad

☞ page 12

### Areas excluding the display

Wipe these areas with a soft cloth, after applying water or detergent diluted with water to the soft cloth and firmly wringing it.

### CAUTION

- Do not use benzene or thinner, or disinfectant-type alcohol.
- Do not directly use water, liquid detergents or spray-type cleaners. If liquid enters the computer, this may cause the computer to malfunction or become defective.

# List of Error Codes



The following is a list of the messages that BIOS can display. Most of them occur during POST. Some of them display information about a hardware device, e.g., the amount of memory installed. Others may indicate a problem with a device, such as the way it has been configured. If your system displays one of the messages marked below with an asterisk (\*), write down the message and contact Panasonic Technical Support. If your system fails after you make changes in the Setup menus, reset the computer, enter Setup and install Setup defaults or correct the error. (☞ Reference Manual "List of Error Codes")

0200 Failure Fixed Disk  
0210 Stuck key  
0211 Keyboard error  
\*0212 Keyboard Controller Failed  
0213 Keyboard locked - Unlock key switch  
0220 Monitor type does not match CMOS - Run SETUP  
\*0230 Shadow RAM Failed at offset : *nnnn*  
\*0231 System RAM Failed at offset : *nnnn*  
\*0232 Extended RAM Failed at offset : *nnnn*  
0250 System battery is dead - Replace and run SETUP  
0251 System CMOS checksum bad - Default configuration used  
\*0260 System timer error  
\*0270 Real time clock error  
0280 Previous boot incomplete - Default configuration used  
0281 Memory Size found by POST differed from CMOS  
02B0 Diskette drive A error  
02B1 Diskette drive B error  
02B2 Incorrect Drive A type - run SETUP  
02B3 Incorrect Drive B type - run SETUP  
02D0 System cache error - Cache disabled  
02F0: CPU ID:  
\*02F4: EISA CMOS not writable  
\*02F5: DMA Test Failed  
\*02F6: Software NMI Failed  
\*02F7: Fail - Safe Timer NMI Failed  
*device* address Conflict  
Allocation Error for: *device*  
CD ROM Drive  
Entering SETUP ...  
Failing Bits : *nnnn*  
Fixed Disk *n*  
Invalid System Configuration Data  
I/O device IRQ conflict  
PS/2 Mouse Boot Summary Screen:  
*nnnn* kB Extended RAM Passed  
*nnnn* Cache SRAM Passed  
*nnnn* kB Shadow RAM Passed  
*nnnn* kB System RAM Passed  
Operating system not found  
\*Parity Check 1 *nnnn*  
\*Parity Check 2 *nnnn*  
Press <F1> to resume, <F2> to Setup, <F3> for previous  
Press <F2> to enter Setup  
PS/2 Mouse:  
System BIOS shadowed  
UMB upper limit segment address : *nnnn*  
Video BIOS shadowed

# Dealing With Problems

When a problem occurs, please refer to this page. The Reference Manual also contains detailed information. If you still cannot troubleshoot the problem, please contact Panasonic Technical Support.

## ● Starting Up

The power indicator or battery indicator is not lit	<ul style="list-style-type: none"> <li>● Check the cable connection for the AC adapter.</li> <li>● Check to see if a fully charged battery is properly installed.</li> <li>● Remove the battery pack and disconnect the AC adapter, then connect them again.</li> </ul>
 or  is displayed	Please input your password. If you have forgotten it, contact Panasonic Technical Support.
[POST Startup Error(s)] is displayed	☞ page 18
The pre-memory count, Windows startup, or an operation is extremely slow	Press <b>(F9)</b> in the Setup Utility (☞ <small>Reference Manual</small> "Setup Utility"). This will restore the Setup Utility's settings to their default values (except the password settings). Then, the Setup Utility must be run once again for you to input the appropriate operating environment settings. (The processing speed depends on the application software used, so this operation may not cause the processing speed to increase.)
The date and time are incorrect	You can set the date and time through [Date/Time] in [Start] - [Settings] - [Control Panel]. If you continue to experience problems, the internal battery maintaining the clock may need to be replaced. Please contact Panasonic Technical Support.
When the previous item is not the cause	<ul style="list-style-type: none"> <li>● Press <b>(F9)</b> in the Setup Utility (☞ <small>Reference Manual</small> "Setup Utility"). This will restore the Setup Utility's settings to their default values (except the password settings).</li> <li>● Try removing all peripheral devices.</li> <li>● In the MS-DOS mode, run SCANDISK to check the hard disk.</li> <li>● At start-up, press <b>(F8)</b> to operate the computer in the Safe mode.</li> </ul>

## ● Battery Indicator

The red indicator lights. Repeated beeping sound while the computer is in use.	The battery level is low. Save your data and power off your computer. After connecting the AC adapter or replacing the battery pack with a fully charged one, turn your computer on.
The red indicator blinks	<ul style="list-style-type: none"> <li>● The battery pack or recharging function may be defective. Quickly remove the battery pack and disconnect the AC adapter, then connect them again.</li> <li>● If the problem persists, contact Panasonic Technical Support.</li> </ul>
After the AC adapter is connected, the orange indicator blinks five times	Unable to charge because of an improper temperature range. (☞ page 4)

## ● Character Input

Unable to input anything but numerals	If NumLk and Key Pad are on, the Numeric Key Pad is ON. To switch it OFF, press <b>(Fn) + (Key Pad)</b> .
Only capital letters are being input	If CapsLock is on, the Caps Lock function is ON. To switch it OFF, press <b>(Caps Lock)</b> .
How to input European characters (ß, à, ç) or symbols is unclear	Select [Start] - [Programs] - [Accessories] - [Character Map]. The Character Map will be displayed. Point to the desired font name and select it.

# Dealing With Problems

## ● Display

<p><b>No display after powering on</b></p>	<ul style="list-style-type: none"> <li>● At the time of purchase, the display setting is preset for an external display. If you connect an external display, the screen is displayed on the external display.</li> <li>● When there is no display to an external display,             <ul style="list-style-type: none"> <li>• Check your cable connection to the external display.</li> <li>• Confirm your display is powered on.</li> <li>• Check the settings for your external display.</li> </ul> </li> <li>● Try changing the display by pressing <b>(Fn) + (F3)</b>.</li> <li>● When displaying only through an external display, if the computer is shut down by using the suspend or hibernation function, there will be no display on the LCD unless the external display is connected when operations are resumed. In this case, connect the external display.</li> </ul>
<p><b>The power has not been cut, but after a certain period of time, there is no display</b></p>	<ul style="list-style-type: none"> <li>● Has the computer been set to the power-saving mode? To resume operation of your computer from ECO mode, press any key.</li> <li>● To save power, your computer may have automatically entered the suspend or hibernation mode. (☞ <small>Reference Manual</small> "Computing On the Road")</li> </ul>
<p><b>The resolution of the display cannot be changed</b></p>	<p>Set [None] for [Wallpaper] in [Start] - [Settings] - [Control Panel] - [Display] - [Background], and then press [OK]. Then, once again try changing the resolution. After the change, be sure to restart the computer.</p>
<p><b>An afterimage appears</b></p>	<p>If an image is displayed for a prolonged period of time, an afterimage may appear. This is not a malfunction. The afterimage will disappear when a different screen is displayed.</p>
<p><b>The motion of the mouse cursor is not smooth</b></p>	<p>Select [Start] - [Settings] - [Control Panel] - [Mouse] - [Motion] and add the check mark ✓ for [Show trails].</p>
<p><b>The cursor does not move in scrolling area of the touch pad</b></p>	<p>When the Microsoft® IntelliMouse™ Wheel mode or the original mode is set for the touch pad, only scroll operations are possible for the right part or bottom part of the touch pad. In this case, cursor operations are possible by using the work surface excluding the right part or bottom part. When no mode is set, the entire surface of the touch pad can be used for cursor operations. (☞ page 12)</p>

## ● Disk Operations

<p><b>Cannot read/write to a floppy disk</b></p>	<ul style="list-style-type: none"> <li>● Has the floppy disk been correctly inserted?</li> <li>● Has the floppy disk been correctly formatted?</li> <li>● Has the Setup Utility been used to set [Floppy Operation] to [Enable]? (☞ <small>Reference Manual</small> "Setup Utility")</li> <li>● Your floppy disk content may be corrupted.</li> </ul>
<p><b>Unable to write to a floppy disk</b></p>	<p>Is the floppy disk write-protected?</p>
<p><b>How to format a floppy disk is unclear</b></p>	<p>Select [Format] in [My Computer] - [3 1/2 Floppy (A:)] - [File]. After confirming the disk volume and format type, start formatting.</p>
<p><b>Unable to read/write to the hard disk</b></p>	<ul style="list-style-type: none"> <li>● Your drive or file may not have been properly set.</li> <li>● Check to see if the hard disk is full. If it is full, delete unnecessary files.</li> <li>● Your hard disk content may be corrupted. Contact Panasonic Technical Support.</li> </ul>
<p><b>When the previous item is not the cause</b></p>	<p>Try testing another drive or media.</p>

## ● Disk Operations

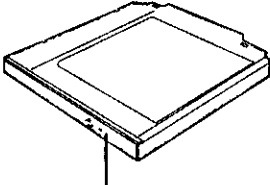
<p>The computer does not recognize the CD-ROM pack</p>	<ul style="list-style-type: none"> <li>● Have you installed the drivers? (☞ <small>Reference Manual</small> "Using a Multimedia Pocket Device")</li> <li>● Did you restart the computer after installing the drivers?</li> <li>● Is the CD-ROM pack properly mounted in the multimedia pocket?</li> </ul>
<p>The access lamp (MP) does not light</p>	<p>Is the CD loaded on the tray correctly?</p>
<p>Cannot play CD or read data from it</p>	<p>Is the CD bent, scratched, or dirty?</p>
<p>Cannot eject CD</p>	<p>Is the computer powered on? To remove a CD when the computer is powered off, insert a sharp object such as the bent-out tip of a paper clip into the emergency hole. Pushing it completely to the end will free the tray so that it can be pulled out.</p> <div style="text-align: center;">  <p>Emergency hole</p> </div>
<p>A blue background appears on the screen with the MPEG image</p>	<p>Did you open the CD-ROM drive or remove the MPEG CD while it was operating? Re-insert the MPEG CD and close the CD-ROM drive. Press <b>Enter</b>.</p>

## ● Key Operation

<p>If you change the video output destination by pressing <b>Fn</b> + <b>F3</b> under the condition the full DOS screen is open (in [Start]-[Programs]-[MS-DOS Prompt]), when you close the MS-DOS screen by typing "Exit", the computer will return to the output destination existing at the time you entered the MS-DOS mode</p>	<p>Press <b>Fn</b> + <b>F3</b> again.</p>
---	---

# Reinstalling Software

## Before Reinstallation

### ● Preparing

- You will need the FIRTAID CD, CD-ROM included in the Windows 95 System Pack and the FIRTAID FD you made earlier.

#### NOTE

If you have not created the FIRTAID FD, you can create by selecting [Create FIRTAID FD] in [Start] - [Programs] - [Panasonic]. If you can not create this disk, please contact Panasonic Technical Support.

- The included CD-ROM pack (CF-VCD711) and the optional FDD cable (CF-VCF351) are required for the following reinstallation procedure.

Mount the CD-ROM pack in the multimedia pocket and connect the FDD cable to the floppy disk drive. (Refer to the operating instructions of the FDD cable for details.)

### ● Important

- Save all important data. If reinstallation is carried out, all data existing prior to the installation will be lost. The reinstallation will return the computer to close to the conditions at time of purchase.
- Before the reinstallation procedure, remove all peripherals (except for the CD-ROM drive and FDD cable).
- Be sure the AC adapter is connected until the reinstallation procedure is completed.

## Reinstalling

### ● Windows 95 (HDD format)

#### CAUTION

If data on your hard disk is compressed, the data should be uncompressed.

- 1 Insert the FIRTAID FD, and turn the computer on.
- 2 When the message [Press F2 to enter Setup] is displayed, press **(F2)** and then run the Setup Utility.  
If the password has been set, enter the supervisor password.
- 3 Press **(F9)**.  
At the confirmation message, select [Yes] and press **(Enter)**.
- 4 Select [Power] menu and set [Power Management] to [Disable] and [Sleep Switch] to [No Action].
- 5 Press **(F10)**.  
At the confirmation message, select [Yes] and press **(Enter)**. The computer will reboot, and this screen should appear.

Microsoft Windows 95 Startup Menu

1. Boot
2. Initialize the HDD for the Hibernation function
3. Restore the HDD to factory default

Enter a choice: 1

- 6 ● To use the hibernation function, follow this procedure and be sure to create the hibernation partition.
  - If you decide not to create the hibernation partition, go on to step 7
- ① Select [2.Initialize the HDD for the Hibernation function].
- ② At the confirmation message, press **(Y)**.
- ③ When the message [Press any key to continue...] is displayed, confirm that the FIRTAID FD has been set in the floppy drive, and then press a key.  
The computer will reboot.

### ● Windows 95 (reinstalling)

- 7 Select [3. Restore the HDD to factory default].
- 8 At the confirmation message, press any key.
- 9 When your computer prompts you to insert the FIRTAID CD, please set the specified CD and press any key.
- 10 When your computer prompts you to insert the "Windows 95 CD-ROM", please set the specified CD and press any key.
- 11 When the [To continue, press ENTER...] appears, press **(Enter)**.  
After Microsoft ScanDisk completes, the computer will automatically return to the Windows 95 setup.  
Simply follow the on-screen instructions.

#### NOTE

- With the exception of the instruction below, please select all default values displayed by the Setup Wizard. Be sure to add the check mark  to [Sound, MIDI, or Video Capture Card] at the [Analyzing Your Computer].
- Have a floppy disk on hand to create a "Windows 95 Startup Disk". Immediately after creating this disk, enter the FIRTAID FD into the floppy disk drive and press [OK]. (Note: A system error will result if the FIRTAID FD is not inserted. If this occurs, insert the FIRTAID FD and press [Retry].)

- 12 At the [Finishing Setup], remove the floppy disk and press [Finish]. Windows will restart after all the settings have automatically been made. If the computer asks you to insert the Windows 95 Disk, press [OK]. Input [c:\cabs], then press [OK].
- 13 At the [Date/Time Properties], press [Close].
- 14 At the [Add Printer Wizard], press [Cancel].
- 15 When the display appears indicating the establishment of the system settings, press [OK]. The computer will reboot.

## ● System setup

- 16 In [Start] - [Run], input [c:\install.bat], then press [OK].  
Rebooting will be done automatically.  
It may take several minutes to reboot the computer.
- 17 In [Start] - [Programs] - [Windows Explorer], delete the "c:\install.bat" and "c:\install.pif" files.

## ● Device manager 1

- 18 In [Start] - [Settings] - [Control Panel] - [System] - [Device Manager], select [PCIC or compatible PCMCIA controller] in [PCMCIA socket]. Remove the check for [Disable in this hardware profile] in [Properties] - [General] and then press [OK].
- 19 Press [Next] at the display for the [Welcome to the PC Card (PCMCIA) Wizard], press [Next] again and then press [Finish].
- 20 The display will ask you to restart Windows, press [No].
- 21 Check [View devices by connection] at [Device Manager] and select [PCI bus] in [Plug and Play BIOS], press [Remove], then press [OK]. The display will ask you to restart Windows, press [Yes]. Rebooting will be done automatically. If the computer asks you to insert the Windows 95 Disk, press [OK]. Input [c:\cabs], then press [OK].
  - Then, when the [Version Conflict] appears, select [Yes].
- 22 Press [Next] at the [Update Device Driver Wizard of Standard PCI Graphics Adapter (VGA)] and [Finish]. The display will ask you to restart Windows, press [Yes].
- 23 Press [Next] at the [Update Device Driver Wizard of PCI Universal Serial Bus] and [Finish]. The display will ask you to restart Windows, press [Yes].

## ● Sound driver

- 24 In [Control Panel] - [System] - [Device Manager], for each item in [Sound, video and game controller], press [Remove] to delete it, then press [OK] to confirm the deletion.
  - At the message to restart the computer, select [No].
- 25 Press [Refresh] and press [Next] at the [Update Device Driver Wizard of Unknown Devices].
- 26 Select [Other Locations], input [c:\util\drivers\sound], then press [OK].
- 27 At the [Update Device Driver Wizard of YAMAHA OPL3-SAx Sound System], press [Finish].

## ● Video driver

- 28 In [Device Manager] - [Display adapters] - [Standard PCI Graphics Adapter (VGA)] - [Driver] - [Update Driver], select [Yes (Recommended).], then press [Next].
- 29 Select [Other Locations], input [c:\util\drivers\video], press [OK], then press [Finish]. The display will ask you to restart Windows, then press [Yes].

## ● Touch pad driver

- 30 In [Start] - [Settings] - [Control Panel] - [Mouse] - [General] - [Change] - [Have Disk], input [c:\util\drivers\mouse] and press [OK]. Select [touch pad], press [OK] and then press [Close]. The display will ask you to restart Windows, then press [Yes].

## ● Power management

- 31 Delete the check mark for [When powered by AC power] and [When powered by batteries] in [Control Panel] - [Power] - [Disk Drives], then press [OK].

## ● Device manager 2

- 32 Add the check mark ✓ for [DMA] in [Control Panel] - [System] - [Device Manager] - [CDROM] - [MATSHITA UJDA150] - [Settings].
- 33 Set [L:] for [Reserved drive letters], then press [OK].
- 34 Add the check mark ✓ for [DMA] in [Device Manager] - [Disk drives] - [GENERIC IDE DISK TYPE\*\*] - [Settings], then press [OK].
- 35 Set [Mobile or docking system] in [Performance] - [File System] - [Hard Disk] - [Typical role of this machine], then press [OK].
- 36 At the [System Properties], press [Close]. The display will ask you to restart Windows, then press [Yes].

## ● Display driver

- 37 Select [Super VGA 1280 X 1024] for [Models] in [Control Panel] - [Display] - [Settings] - [Advanced Properties] - [Monitor] - [Change], then press [OK].
- 38 Confirm that there is a check mark ✓ for [Automatically detect Plug & Play monitors] in [Options] for the [Monitor].
- 39 Select [Apply the changes without restarting] in [Compatible] for the [Performance], and then press [Close].
- 40 Set [High Color (16 bit)] for the [Color palette], set [1024 X 768] for the [Desktop area] and then press [OK].
  - Select [OK] at the [Display Properties], and select [YES] at the [Do you want to keep this setting?]. If after a short period of time no action is taken for the [Do you want to keep this setting?], the [Windows has restored your original display settings] will appear. Select [OK] and perform the display settings again.

## ● DMI Viewer setup

- 41 Insert the FIRSTAIID CD.
- 42 In [Start] - [Run], input [L:\en\dm\setup.exe], then press [OK].  
DMI Viewer setup will start automatically. Follow the on-screen instructions. The display will ask you to restart Windows; press [Finish].

## ● Panasonic Hand Writing setup

- 43 Insert the FIRSTAIID CD.
- 44 In [Start] - [Run], input [L:\en\writing\setup.exe], then press [OK].  
Panasonic Hand Writing Setup will start automatically. Simply follow the on-screen instructions.

# Reinstalling Software

## ● Infrared

- 45 Select [Control Panel] - [Add New Hardware].
- 46 Press [Next] at the [Add New Hardware Wizard].
- 47 Select [No], then press [Next].
- 48 Select [Infrared] in [Hardware types] and press [Next].
- 49 Press [Next], and press [Next] again.
- 50 Select [Generic Ir Serial Port [COM2]] in [Select the port that infrared device.....].
- 51 From here on, follow the instructions given on the display followed by pressing [Next].  
If the computer asks you to insert the Windows 95 Disk, press [OK]. Input [c:\cabs], then press [OK].
- 52 Press [Finish].

## Installing Internet Explorer 4.0

Reinstalling Windows causes an older version of Internet Explorer to be installed.

To return the computer to the state it was in when you purchased it, follow the steps below to install the newer version of Internet Explorer.

- 1 Insert the Windows 95 CD-ROM included in the Windows 95 System Pack.
- 2 In [Start] - [Run], input [L:\win95\ie4setup.exe], then press [OK].
- 3 At the [Internet Explorer 4.0 Active Setup], press [Next].
- 4 Read the [License Agreement] and select [I accept the agreement], then press [Next].
- 5 At the display for [Installation Option], by selecting , select [Full Installation] and then press [Next].  
Follow the on-screen instructions.  
When the message indicating the end of the installation operation appears, select [OK].
  - If a display with the message [Setup was unable to close all programs automatically.] appears, when there is a program in operation, save all data and then select [OK].
- 6 The display will ask you to restart Windows, then press [Yes].

## Installing Acrobat® Reader 3.01

☞ page 10, Step 8

## Installing Support for the euro currency symbol

- 1 In [Start] - [Run], input [c:\util\msupdate\W95\_euro.exe], then press [OK].
- 2 The display will ask you to restart Windows, then press [Yes].

## Port Replicator (Option)

After reinstalling the software on the hard disk, different settings are necessary when using the port replicator. Execute the following steps. (Please ignore the reinstalling steps in the operating instructions that accompany the port replicator.)

- 1 Turn the computer on.
- 2 When the message [Press F2 to enter Setup] is displayed, press **F2** and then run the Setup Utility.
- 3 In [Advanced] menu, set [Internal CardBus Controller] to [Disable].
- 4 Press **F10**.  
At the confirmation message, select [Yes] and press **Enter**.
- 5 Power off your computer. Do not shut down using the suspend or hibernation function.
- 6 Place the computer on top of the port replicator.
- 7 Turn your computer on.
  - If the computer asks you to insert the Windows 95 Disk, press [OK]. Input [c:\cabs], then press [OK].
  - Then, when the [Version Conflict] appears, select [Yes]. At the [Configuration Setup], press [OK].
- 8 At the [Configuration Setup], press [OK].
- 9 Select [Super VGA 1280 X 1024] for [Models] in [Start] - [Settings] - [Control Panel] - [Display] - [Settings] - [Advanced Properties] - [Monitor] - [Change], then press [OK].
- 10 Confirm that there is a check mark  for [Automatically detect Plug & Play monitors] in [Options] for the [Monitor], and then press [Close].
- 11 Set [High Color (16 bit)] for the [Color palette], set [1024 X 768] for the [Desktop area] and then press [OK]. The display will ask you to restart Windows, press [No].
  - Do not select [1024 X 480] for the [Desktop area].
  - If [Compatibility Warning] is displayed, select [Apply the settings without restarting?] and press [OK]. After that, select [OK] at the [Display Properties], and select [YES] at the [Do you want to keep this setting?].  
If after a short period of time no action is taken for the [Do you want to keep this setting?], the [Windows has restored your original display settings] will appear. Select [OK] and perform the display settings again.
- 12 In [Start] - [Shut Down], select [Shut down], then press [OK].
- 13 Turn your computer on.
- 14 Select [PC Card (PCMCIA)] in [Control Panel].
- 15 Press [Next] at the display for the [Welcome to the PC Card (PCMCIA) Wizard], press [Next] again and then press [Finish].
- 16 At the [System Settings Change], press [No].
- 17 In [Start] - [Shut Down], select [Shut down], then press [OK].



# LIMITED USE LICENSE AGREEMENT

THE SOFTWARE PROGRAM(S) ("PROGRAMS") FURNISHED WITH THIS PANASONIC® PRODUCT ("PRODUCT") ARE LICENSED ONLY TO THE END-USER ("YOU"), AND MAY BE USED BY YOU ONLY IN ACCORDANCE WITH THE LICENSE TERMS DESCRIBED BELOW. YOUR USE OF THE PROGRAMS SHALL BE CONCLUSIVELY DEEMED TO CONSTITUTE YOUR ACCEPTANCE OF THE TERMS OF THIS LICENSE.

Matsushita Electric Industrial Co., Ltd. ("MEI") has developed or otherwise obtained the Programs and hereby licenses their use to you. You assume sole responsibility for the selection of the Product (including the associated Programs) to achieve your intended results, and for the installation, use and results obtained therefrom.

## LICENSE

- A. MEI hereby grants you a personal, non-transferable and non-exclusive right and license to use the Programs in accordance with the terms and conditions stated in this Agreement. You acknowledge that you are receiving only a LIMITED LICENSE TO USE the Programs and related documentation and that you shall obtain no title, ownership nor any other rights in or to the Programs and related documentation nor in or to the algorithms, concepts, designs and ideas represented by or incorporated in the Programs and related documentation, all of which title, ownership and rights shall remain with MEI or its suppliers.
- B. You may use the Programs only on the single Product which was accompanied by the Programs.
- C. You and your employees and agents are required to protect the confidentiality of the Programs. You may not distribute or otherwise make the Programs or related documentation available to any third party, by time-sharing or otherwise, without the prior written consent of MEI.
- D. You may not copy or reproduce, or permit to be copied or reproduced, the Programs or related documentation for any purpose, except that you may make one (1) copy of the Programs for backup purposes only in support of your use of the Programs on the single Product which was accompanied by the Programs. You shall not modify, or attempt to modify, the Programs.
- E. You may transfer the Programs and license them to another party only in connection with your transfer of the single Product which was accompanied by the Programs to such other party. At the time of such a transfer, you must also transfer all copies, whether in printed or machine readable form, of every Program, and the related documentation, to the same party or destroy any such copies not so transferred.
- F. You may not remove any copyright, trademark or other notice or product identification from the Programs and you must reproduce and include any such notice or product identification on any copy of any Program.

YOU MAY NOT REVERSE ASSEMBLE, REVERSE COMPILE, OR MECHANICALLY OR ELECTRONICALLY TRACE THE PROGRAMS, OR ANY COPY THEREOF, IN WHOLE OR IN PART.

YOU MAY NOT USE, COPY, MODIFY, ALTER, OR TRANSFER THE PROGRAMS OR ANY COPY THEREOF, IN WHOLE OR IN PART, EXCEPT AS EXPRESSLY PROVIDED IN THE LICENSE.

IF YOU TRANSFER POSSESSION OF ANY COPY OF ANY PROGRAM TO ANOTHER PARTY, EXCEPT AS PERMITTED IN PARAGRAPH E ABOVE, YOUR LICENSE IS AUTOMATICALLY TERMINATED.

## TERM

This license is effective only for so long as you own or lease the Product, unless earlier terminated. You may terminate this license at any time by destroying, at your expense, the Programs and related documentation together with all copies thereof in any form. This license will also terminate effective immediately upon occurrence of the conditions therefor set forth elsewhere in this Agreement, or if you fail to comply with any term or condition contained herein. Upon any such termination, you agree to destroy, at your expense, the Programs and related documentation together with all copies thereof in any form.

YOU ACKNOWLEDGE THAT YOU HAVE READ THIS AGREEMENT, UNDERSTAND IT AND AGREE TO BE BOUND BY ITS TERMS AND CONDITIONS. YOU FURTHER AGREE THAT IT IS THE COMPLETE AND EXCLUSIVE STATEMENT OF THE AGREEMENT BETWEEN US, WHICH SUPERSEDES ANY PROPOSAL OR PRIOR AGREEMENT, ORAL OR WRITTEN, AND ANY OTHER COMMUNICATIONS BETWEEN US, RELATING TO THE SUBJECT MATTER OF THIS AGREEMENT.

# Contrat de licence d'usage limité

Le(s) logiciel(s) (les "Logiciels") fournis avec ce produit Panasonic® (le "Produit") sont exclusivement concédés en licence à l'utilisateur ultime ("vous"), et ils ne peuvent être utilisés que conformément aux clauses contractuelles ci-dessous. En utilisant les logiciels, vous vous engagez de manière définitive à respecter les termes, clauses et conditions des présentes.

Matsushita Electric Industrial Co., Ltd. ("MEI") a mis au point ou obtenu les Logiciels et vous en concède l'utilisation par les présentes. Vous assumez l'entière responsabilité du choix de ce Produit (y compris des Logiciels associés) pour obtenir les résultats escomptés, ainsi que de l'installation, de l'utilisation et des résultats obtenus.

## Licence

- A. MEI vous octroie par les présentes le droit et la licence personnels, non cessibles et non exclusifs d'utiliser les Logiciels conformément aux termes, clauses et conditions de ce Contrat. Vous reconnaissez ne recevoir qu'un droit limité d'utiliser les Logiciels et la documentation les accompagnant et vous vous engagez à n'obtenir aucun droit de titre, propriété ni aucun autre droit vis-à-vis des Logiciels et de la documentation les accompagnant ni vis-à-vis des algorithmes, concepts, dessins, configurations et idées représentés par ou incorporés dans les Logiciels et la documentation les accompagnant, dont les titres, propriété et droits resteront tous à MEI ou à leurs propriétaires.
- B. Vous ne pouvez utiliser les Logiciels que sur le Produit unique qui est accompagné par les Logiciels.
- C. Vous et vos employés ou agents êtes requis de protéger la confidentialité des Logiciels. Vous ne pouvez ni distribuer ni mettre les Logiciels et la documentation les accompagnant à la disposition d'un tiers, par partage de temps ou de quelque autre manière que ce soit, sans l'autorisation écrite préalable de MEI.
- D. Vous ne pouvez ni copier ni reproduire ni permettre la copie ni la reproduction des Logiciels ni de la documentation les accompagnant pour quelque fin que ce soit, à l'exception d'une (1) copie des Logiciels à des fins de sauvegarde uniquement pour soutenir votre utilisation des Logiciels sur le Produit unique qui est accompagné par les Logiciels. Vous ne pouvez ni modifier ni tenter de modifier les Logiciels.
- E. Vous ne pouvez céder les Logiciels et en octroyer la licence à une autre partie qu'en rapport avec votre cession du Produit unique qui est accompagné par les Logiciels à cette autre partie. Au moment de cette cession, vous devez céder également toutes les copies, que ce soit sous forme imprimée ou lisible par la machine, de tous les Logiciels ainsi que de la documentation les accompagnant, à la même partie ou détruire les copies non cédées.
- F. Vous ne pouvez retirer aucune marque de droits d'auteur, marque ou autre ni aucune identification de produit des Logiciels et vous devez reproduire et inclure toutes ces notices ou identifications de produit sur toutes les copies des Logiciels.

Vous ne pouvez assembler en sens inverse, compiler en sens inverse ni retracer les Logiciels ni aucune de leurs copies, de façon électronique ou mécanique, en tout ou en partie.

Vous ne pouvez utiliser, copier, modifier, altérer ni céder les Logiciels ni aucune de leurs copies, en tout ou en partie, à l'exception de ce qui est expressément stipulé dans ce contrat.

Si vous cédez la possession de toute copie ou de tout Logiciel à une autre partie, à l'exception de ce qui est autorisé au paragraphe E ci-dessus, votre licence est automatiquement résiliée.

## Termes, clauses et conditions

Cette licence n'est effective que pour la durée de possession ou de crédit-bail du Produit, à moins d'une résiliation antérieure. Vous pouvez résilier cette licence à tout moment en détruisant, à vos frais, les Logiciels et la documentation les accompagnant avec toutes leurs copies, sous quelque forme que ce soit. Cette licence sera également résiliée, avec application immédiate, si les conditions de résiliation définies ailleurs dans ce contrat se sont réalisées ou si vous ne respectez pas les termes, clauses et conditions qui y sont contenues. Au moment de la résiliation, vous acceptez de détruire, à vos frais, les Logiciels et la documentation les accompagnant avec toutes leurs copies, sous quelque forme que ce soit.

Vous reconnaissez avoir lu ce contrat, en avoir compris toute la substance et avoir accepté de respecter ses termes, clauses et conditions. Vous reconnaissez en outre qu'ils sont la description complète et exclusive du contrat conclu entre nous, contrat qui remplace et annule toute proposition ou contrat précédent, écrit ou oral, et toute autre communication entre nous, relativement à l'objet du présent contrat.

# Names and Functions of Parts

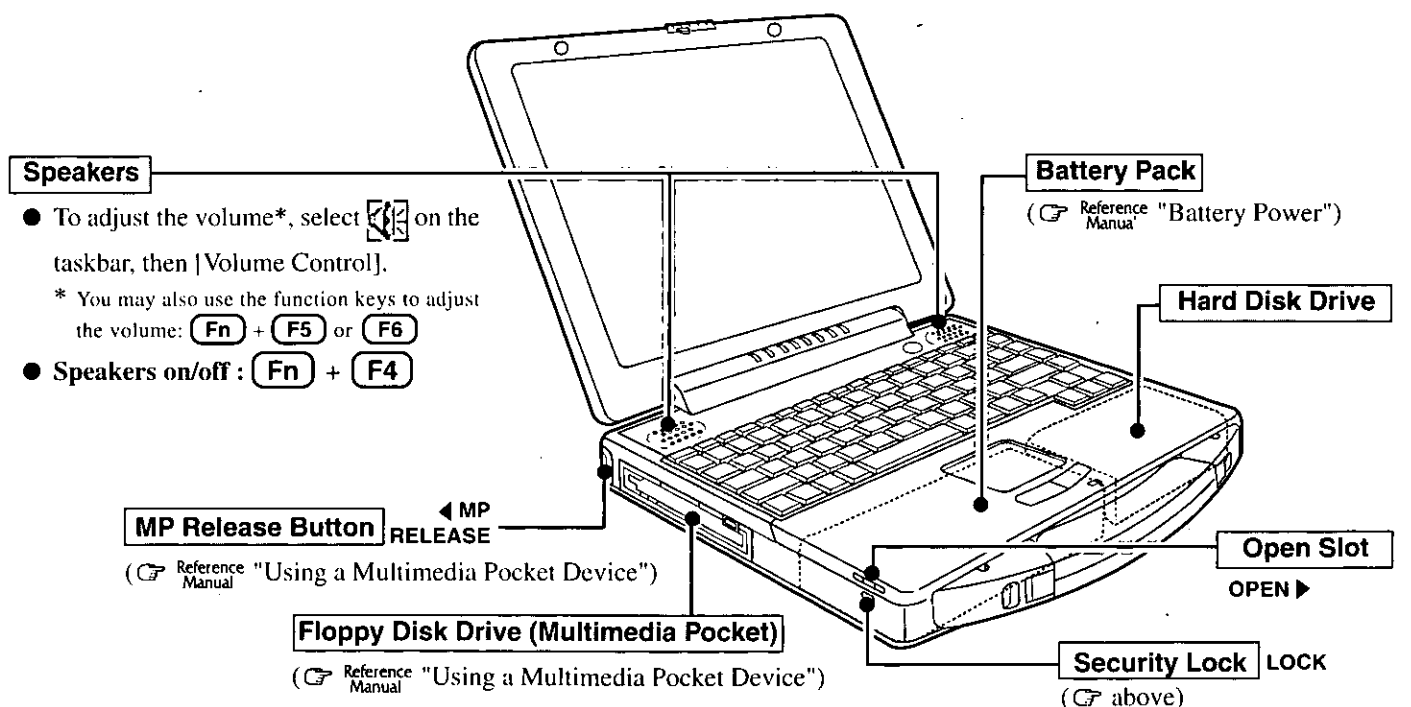
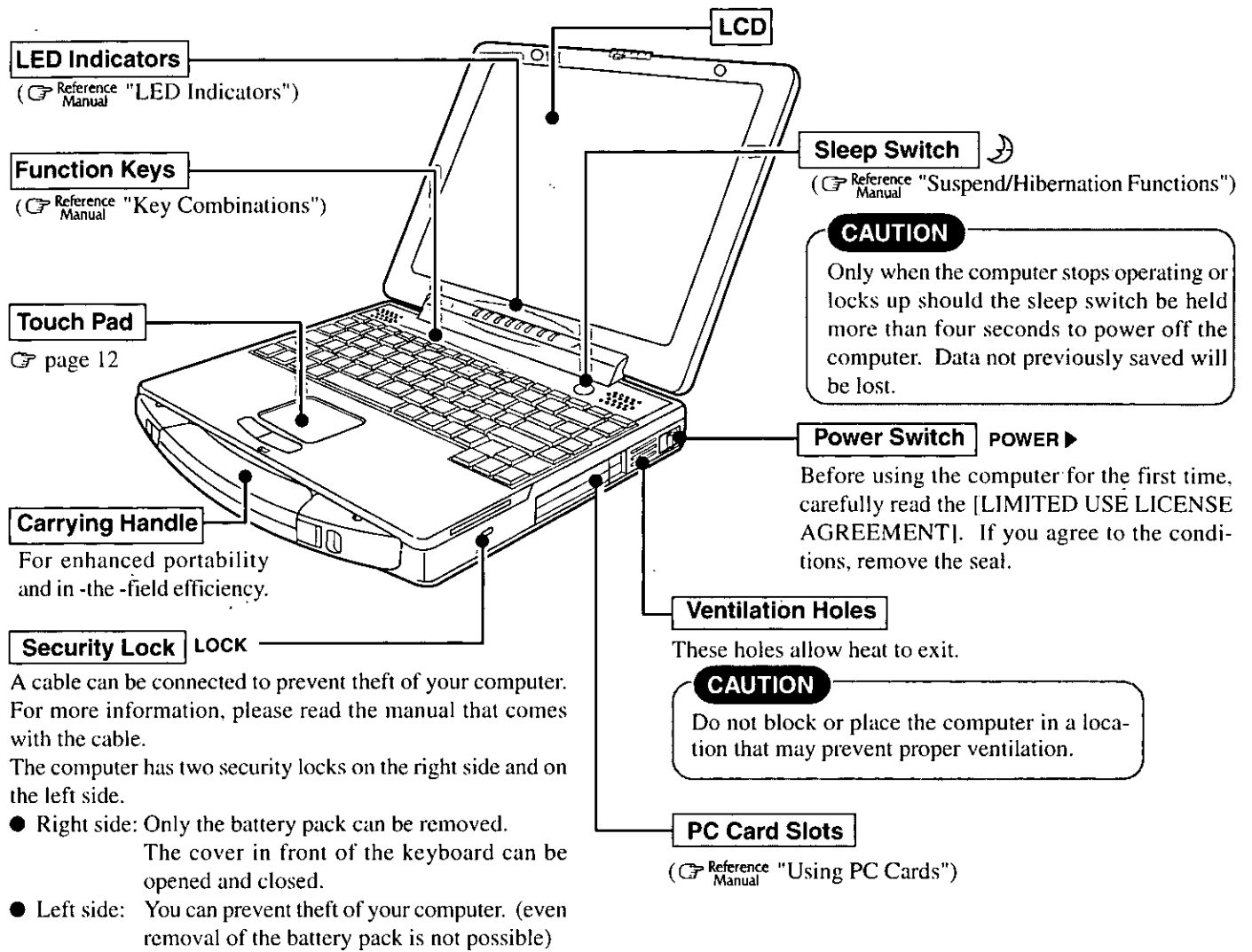

# Names and Functions of Parts

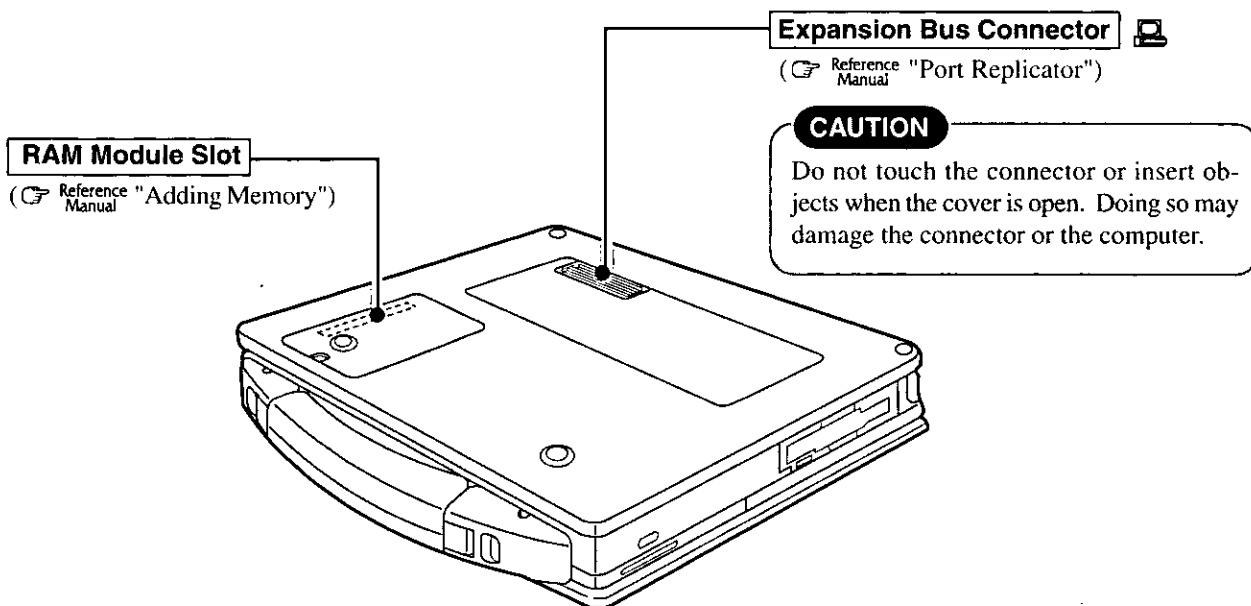
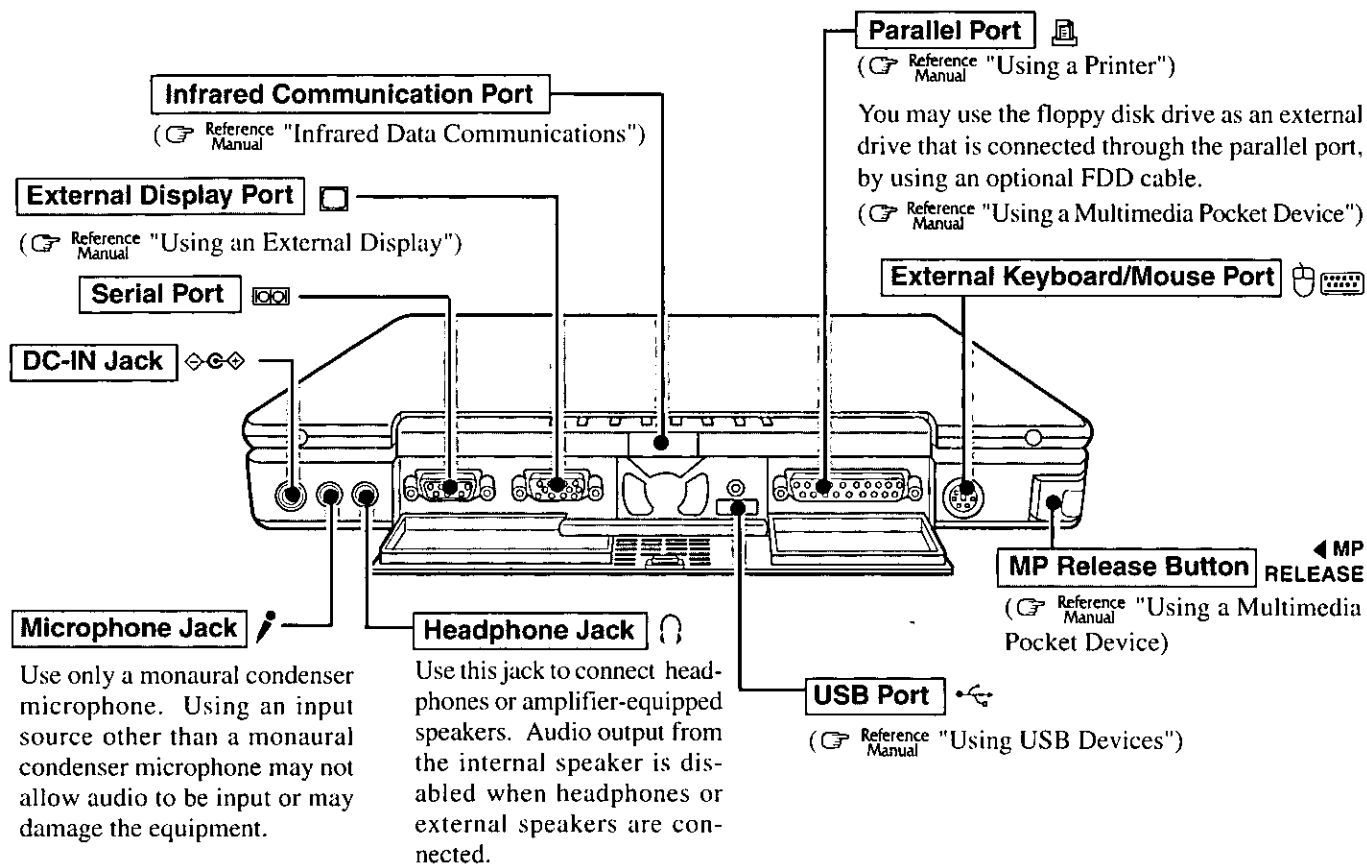

# Specifications

## ● Main Specifications

<b>Model No.</b>		CF-71EY6GBAM
<b>CPU</b>		Mobile Pentium®II Processor 300 MHz
<b>Main Memory (Expandable to)</b>		64 MB (192 MB Max. )
<b>Video Memory</b>		2.5 MB
<b>LCD</b>	<b>Type</b>	13.3" (TFT)
	<b>Displayed Colors*1</b>	256/65536/262144 colors (640 x 480 dots/800 x 600 dots/1024 x 768 dots/1280 x 1024 dots)
<b>Hard Disk Drive (including about 200 MB used specifically by the system)</b>		6.4 GB*2

\*1 800 x 600 16-color resolution is not supported. If this resolution is selected, the message "There is an error in the display settings" will appear when you reboot. Start up again, selecting 256 Color, High Color (16 bit), or True Color (24 bit), following the on-screen instructions. Besides this phenomenon, you might encounter some unexpected behavior. Do not select 16 color mode in any resolution.

\*2 1GB = 10<sup>9</sup> bytes

## ● Other Specifications

<b>Keyboard</b>	Windows 95 keyboard (87 keys)			
<b>Floppy Disk Drive</b>	720 KB/1.44 MB (two-mode)			
<b>CD-ROM Pack</b>	<b>Operating voltage range</b>	DC 5 V±5%		
	<b>Data transfer rate*1</b>	150 KB/sec (Standard) 3600 KB/sec 24x Speed (Max.)		
	<b>Access time</b>	150 ms (24x Speed, 1/3 Stroke*2)		
	<b>Interface</b>	Conforms to enhanced IDE (ATAPI) standard		
<b>Slots</b>	<b>PC Card Slots</b>	Two Type I or Type II, or one Type III		
		<b>Allowable current (total for two slots)</b>	3.3 V: 400 mA, 5 V: 400 mA, 12 V: 120 mA	
	<b>RAM Module Slot</b>	144-pin, SO-DIMM, 3.3 V, SDRAM		
<b>Interface</b>	<b>Parallel Port</b>	Dsub 25-pin female		
	<b>External Display Port</b>	Mini Dsub 15-pin female		
	<b>Serial Port</b>	Dsub 9-pin male		
	<b>Microphone Jack*3</b>	Miniature jack, 3.5 DIA Input impedance 600 Ω, Input voltage range 0.01 Vp-p		
	<b>Headphone Jack</b>	Miniature jack, 3.5 DIA Impedance 32 Ω, Output Power 4 mW (Impedance 32 Ω) x 2		
	<b>Infrared Communication Port</b>	IrDA 1.1 compliant, 4 Mbps data transmission speed*4		
	<b>External Keyboard/Mouse Port</b>	Mini DIN 6-pin female		
	<b>Expansion Bus Connector</b>	Dedicated 200-pin female		
	<b>USB Port</b>	4-pin		
<b>Pointing Device</b>	Touch Pad			
<b>Speakers</b>	Stereo Speakers (built in)			
<b>Sound</b>	16 bits, 44.1 kHz PCM/FM sound (Sound Blaster PRO Compatible)			
<b>Software</b>	<b>Operating System</b>	Microsoft® Windows® 95 (FAT32 File System)		
	<b>Utility Programs</b>	Setup Utility, DMI Viewer, Panasonic Hand Writing		
<b>Battery</b>	<b>Battery Pack</b>	Lithium Ion 10.8 V, 4500 mAh		
	<b>Operating Time</b>	Approx. 2.0 - 4.5 hours*5		
	<b>Charging Time</b>	<b>Power On</b>	Approx. 5.5 hours*5	
		<b>Power Off</b>	Approx. 3.0 hours*5	
	<b>Clock Battery</b>	Coin type lithium battery 3.0 V		
		<b>Operating Time</b>	Approx. 7 years	
<b>AC Adapter*6</b>	<b>Input</b>	100 - 240 V AC, 50 / 60 Hz	<b>Output</b> 15.6 V DC, 3.85A	
<b>Power Consumption</b>	Approx. 50 W*7 (maximum when recharging in the ON state)			
<b>Physical Dimensions (W x H x D)</b>	297 mm X 44.6 mm X 240 mm (11.7 " X 1.8 " X 9.4 ") (Not including the carrying handle)			
<b>Weight</b>	Approx. 3.0 kg (Approx. 6.7 lbs.) (Not including the carrying handle)			

\*1 If an unbalanced disc (i.e., a disc with which the balance has been displaced from the center) is inserted, the speed may become slower if there are large vibrations while the CD is rotating.

\*2 Stroke: Indicates the amount of movement the lens (pickup) of the CD-ROM pack must make in order to read data.

\*3 Use only a monaural condenser microphone.

\*4 A communications software is necessary.

\*5 Varies depending on the usage conditions.

\*6 The AC adapter is compatible with power sources up to 240 V AC adapter. This computer is supplied with a 125 V AC compatible AC cord.

\*7 Approx. 1.5 W when the battery pack is fully charged (or not being charged) and the computer is OFF.

# Memo

---



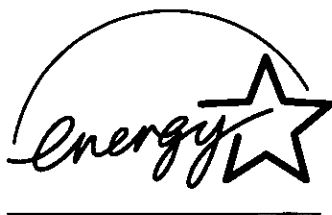

As an ENERGY STAR® Partner, Panasonic has determined that this product meets the ENERGY STAR® guidelines for energy efficiency.

**Outline of the International ENERGY STAR® Office Equipment Program**

The international ENERGY STAR® Office Equipment Program is an international program that promotes energy saving through the use of computers and other office equipment. The program backs the development and dissemination of products with functions that effectively reduce energy consumption. It is an open system in which business proprietors can participate voluntarily. The targeted products are office equipment such as computers, displays, printers, facsimiles, and copiers. Their standards and logos are uniform among participating nations.